

VALVOLE A SFERA
BALL VALVES

ROBINETS À BOULE
KUGELHÄHNE



ALFA®
VALVOLE s.r.l.



ALFA 24K PN 40 ÷ 63

Proprietà riservata - A termine delle vigenti leggi questo documento non potrà essere copiato, riprodotto o comunicato ad altre persone o a ditte senza la nostra autorizzazione scritta
All rights reserved - No part of this reproduced or transmitted, in any form or by any means, electronic, mechanical, photocopying, recording or otherwise, without the prior permission of ALFA VALVOLE s.r.l.



UNI EN ISO 9001:2008
Nr. 50 100 6417 - Rev.3



CE 0948-Modulo H
Certificato nr. PED-0948-OSH-385-13



Consorzio Europeo Certificazione
CEC-06/2037-ADF176
Directive 94/9/EC - Article 8 (1) b) i)

Ed. 0008/02.16

Le caratteristiche delle valvole, con esclusione di quelle regolamentate da Norme internazionali, possono essere oggetto di modifiche senza preavviso
Design and specifications are subject to change without notice except those established by international standards.



ALFA®
VALVOLE s.r.l.

20010 CASOREZZO (Milano) -Italia-
VIALE DEL LAVORO, 19
Tel. 02.90296206 r.a. - Telefax 02.90296292
E-Mail: alfavalvole@alfavalvole.it - Sito Internet: www.alfavalvole.it

BALL VALVES FULL BORE

ALFA 24K

PN 40 ÷ 63

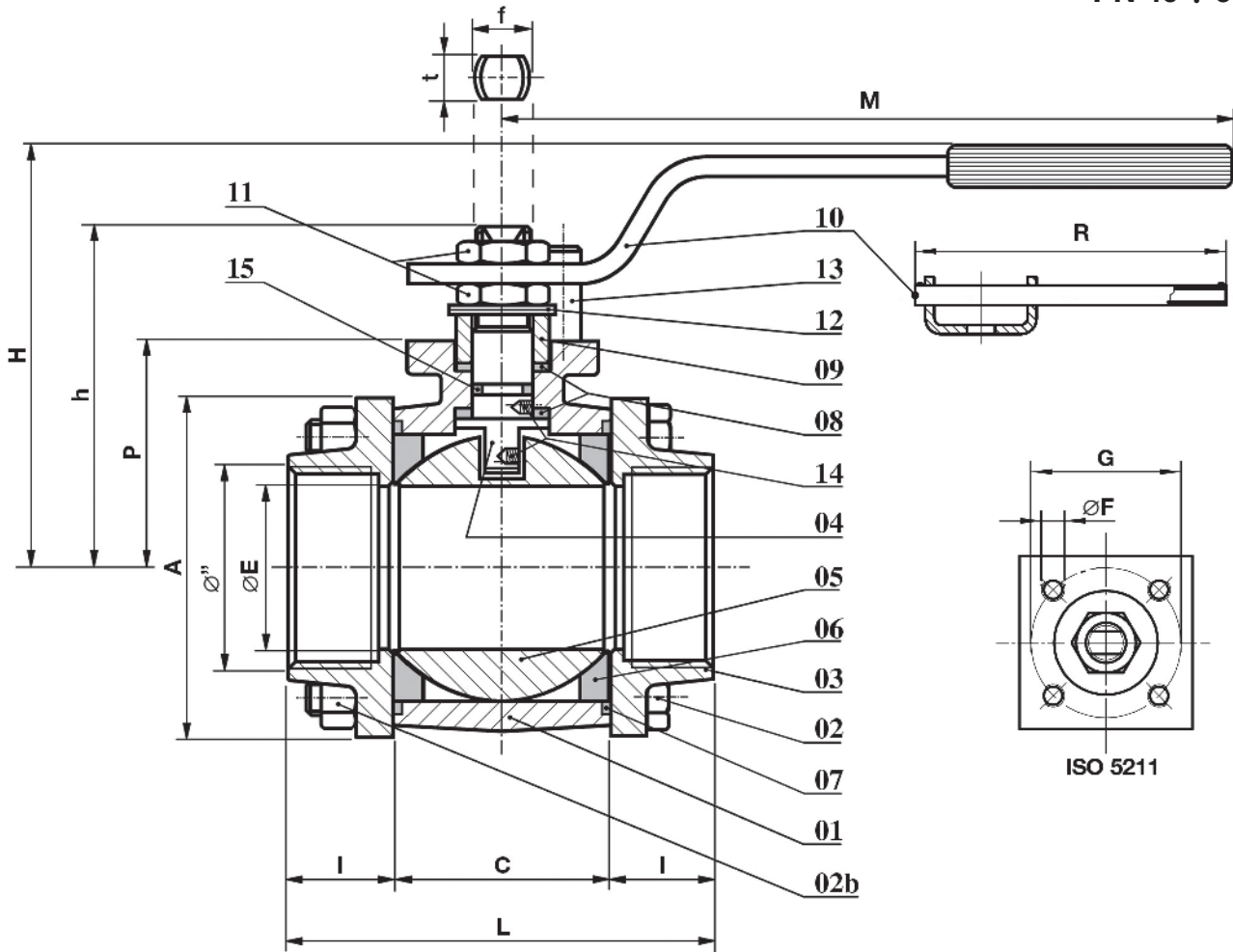

ACCOPPIAMENTO VALVOLA / ATTUATORE.
COUPLING VALVE / ACTUATOR.
ACCOMPLEMENT VANNE / ACTIONNEUR.
ANTRIEB / KUGELHAHN KUPPLUNG.

SCARTAMENTO DIN 3202 M3
FACE TO FACE ACCORDING TO DIN 3202 M3
ENGOMBREMENT SELON DIN 3202 M3
BAULANGE DIN 3202 M3

DIMENSIONI - DIMENSIONS - DIMENSIONS - ABMESSUNGEN

DN	06	10	15	20	25	32	40	50	65	80	100
Ø"	1/4"	3/8"	1/2"	3/4"	1"	1.1/4"	1.1/2"	2"	2.1/2"	3"	4"
ØE	10	10	14	19	24	29	38	48	64	76	95
L (GAS/NPT)	50	60	75	80	90	110	120	140	185	205	240
L (B.W./S.W.)											
M / R	145 / -	145 / -	150 / -	150 / -	185 / -	185 / -	275 / -	275 / -	380 / -	380 / -	440 / 500
H	53	53	84	87	95	99	118	125	143	149	185
h	40.5	40.5	52	54	69	72	95	101	122	127	151
P	25	25	33	36	43	48	63	67	82	88.5	105
A	38	38	47	53.5	61	67.5	82	96	120	184	216
C	20	20	26	31	35	42	52	64	90	100	125
I	15	20	24.5	24.5	27.5	34	34	38	47.5	52.5	57.5
f/t	8/5.7	8/5.7	10/6	10/6	12/8	12/8	16/10	16/10	22/14	22/14	30/18
02/02b	4/M5X40	4/M5X40	4/M6X50	4/M6X55	4/M8X65	4/M8X75	4/M10X90	4/M10X105	4/M12X135	6/M14X150	6/M14X180
Kg.	0.42	0.45	0.76	0.98	1.43	2.00	3.50	5.30	11.30	15.00	25.00
PN	64	64	64	64	64	64	64	40	40	40	40
ISO 5211	F03	F03	F03	F03	F03	F03	F05	F05	F07	F07	F10
ØF	M5	M5	M5	M5	M5	M5	M6	M6	M8	M8	M10
G	36	36	36	36	36	36	50	50	70	70	102

Ed. 0008 / 02.16 / P0002

Le caratteristiche delle valvole, con esclusione di quelle regolamentate da Norme internazionali, possono essere oggetto di modifiche senza preavviso.
Design and specifications are subject to change without notice except those established by international standards.



20010 CASOREZZO (Milano) - Italia -
VIALE DEL LAVORO, 19
Tel. 02.90296206 r.a. - Telefax 02.90296292 -
E-Mail: alfavalvole@alfavalvole.it - www.alfavalvole.it

MATERIALI - MATERIALS - MATERIAUX - WERKSTOFFE

01	CORPO	BODY	CORPS	GEHÄUSE	ASTM A216 WCB	ASTM A351 CF8M
02	VITE	SCREW	VIS	SCHRAUBE	8.8 UNI 3740 ZINCATO - GALVANIZED - ZINGUE - VERZINKT	
02b	DADO CORPO	BODY STUD NUTS	CORPS ECROU	MUTTER GEHÄUSE	6S UNI 3740 ZINCATO - GALVANIZED - ZINGUE - VERZINKT	
03	CHIUSURA	CLOSURE	EMBOUT	FLANSCHSTUTZEN	ASTM A216 WCB	ASTM A351 CF8M
04	STELO	STEM	TIGE	SPINDEL	AISI 410	ASTM A479 F316
05	SFERA	BALL	BOULE	KUGEL	ASTM A479 F304	ASTM A479 F316
06	SEDI	SEATS	SIEGE	SITZRING	R.P.T.F.E.	
07	GUARNIZIONE CORPO	BODY GASKET	ANNEAU	DICHTUNGSRING	P.T.F.E. + GRAF.	P.T.F.E.
08	BUSSOLA	WASHER	JOINT DE TIGE	SPINDELABDICHTUNG	P.T.F.E. + GRAF.	P.T.F.E.
09	PREMIGUARNIZIONE	GLAND	PRESSE ETOUPE	STOPFBÜCHSE	CF9SMnPb36 UNI 4838 ZINCATO - GALVANIZED - ZINGUE - VERZINKT	ASTM A479 F304
10	LEVA	LEVER	LEVIER	HANDHEBEL	Fe37 UNI 7070 ZINCATO - GALVANIZED - ZINGUE - VERZINKT	
11	DADO CONTRODADO	NUT / LOCK NUT	ECROU / CONTRE ECROU	MUTTER / KONTERMUTTER	6S UNI 3740 ZINCATO - GALVANIZED - ZINGUE - VERZINKT	
12	MOLLE A TAZZA	SPRING WASHER	RONDELLES BELLEVILLE	TELLERFEDER	50CrV4 UNI 3545 ZINCATO - GALVANIZED - ZINGUE - VERZINKT	
13	DISPOSITIVO D'ARRESTO	STOP DEVICE	PLOT D'ARRET	ANSCHLAG VORRICHTUNG	8.8 UNI 3740 ZINCATO - GALVANIZED - ZINGUE - VERZINKT	
14	DISPOSITIVO ANTISTATICO	ANTISTATIC DEVICE	CONTACT ANTISTATIQUE	ANTISTATISCHE VORRICHTUNG	ASTM A479 F316	
15	O'RING STELO	STEM O'RING	O'RING TIGE	SPINDEL O'RING	VITON	

- ALFA GARANTISCE DAL 1971 UGUALI PARTI DI RICAMBIO. - ALFA FAIT GARANTIE POUR EGALES PARTIES D'ECHANGE DES 1971.
- ALFA GUARANTEES SPARE PARTS FOR SUPPLIES SINCE 1971. - ALFA GARANTIERT ERSATZTEILE FÜR LIEFERUNGEN SEIT 1971.

DIAGRAMMA - DIAGRAM - DIAGRAMME - DIAGRAMM

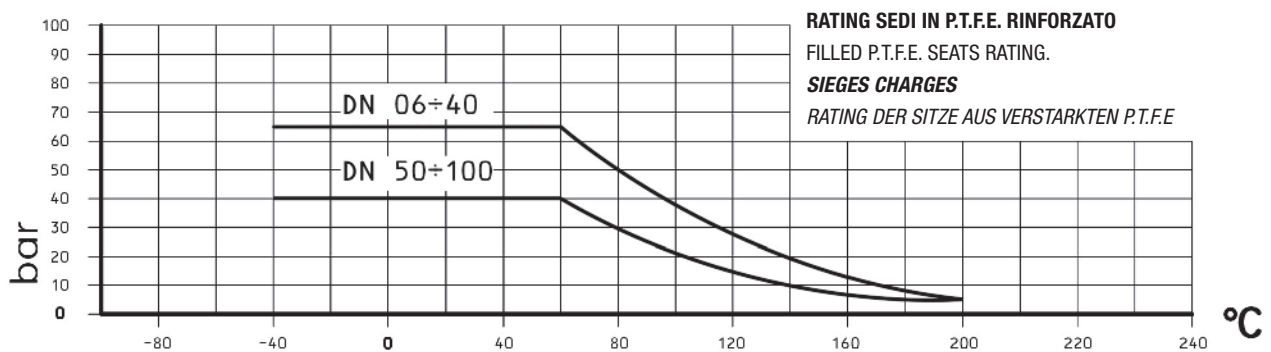

I valori riportati nei diagrammi sono puramente indicativi e possono variare in funzione delle condizioni di esercizio (fluido-pressione-temperatura).



ESECUZIONI - EXECUTIONS - EXECUTIONS - BESCHREIBUNG

STANDARD

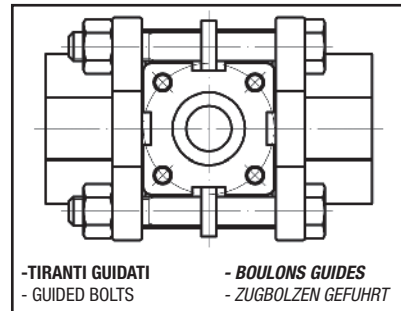
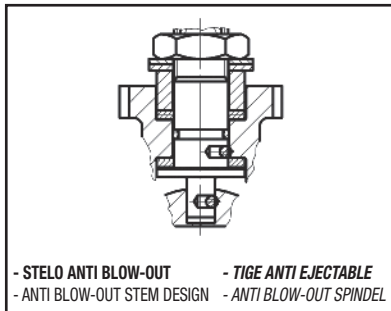
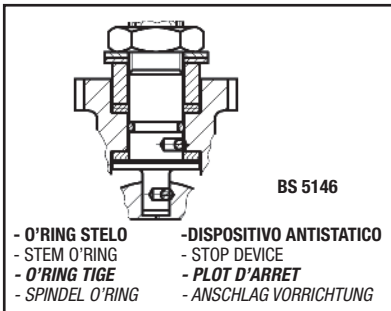
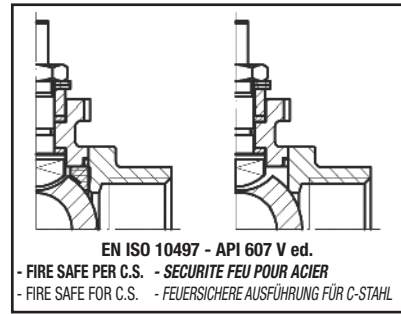
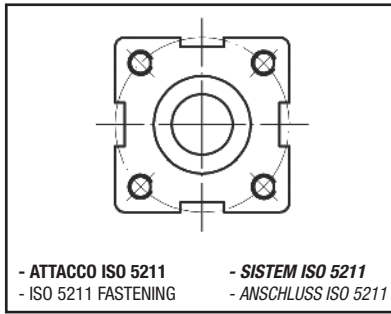
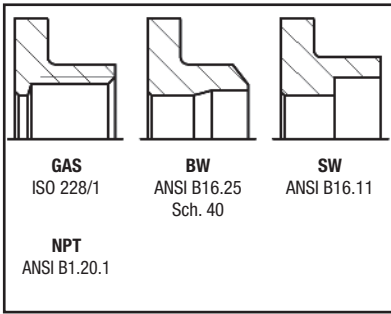

OPTIONAL

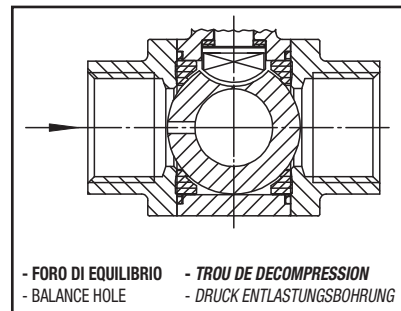
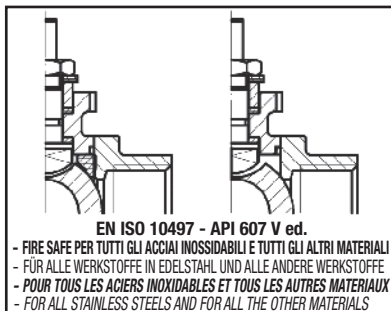
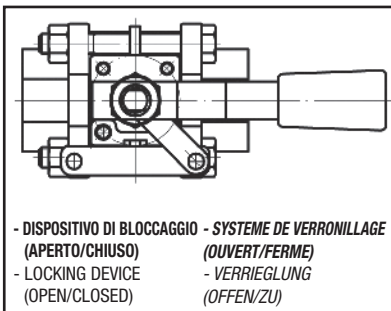
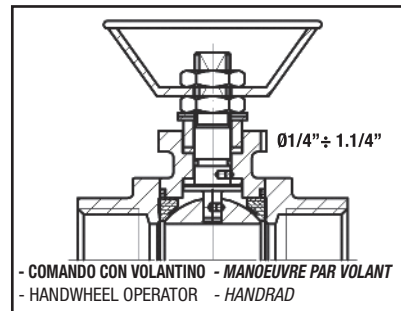
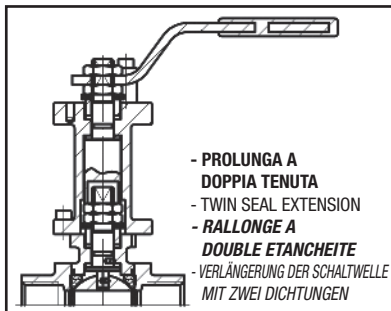
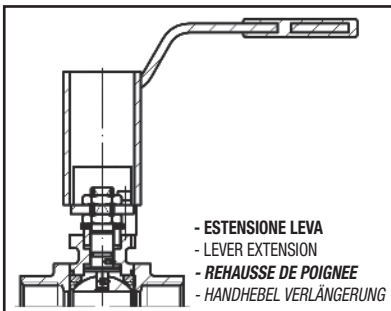
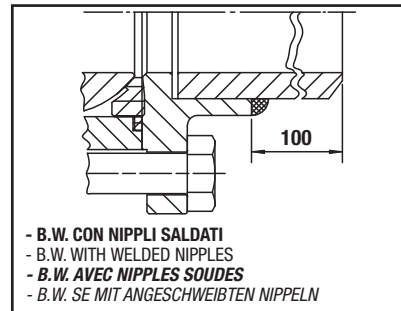
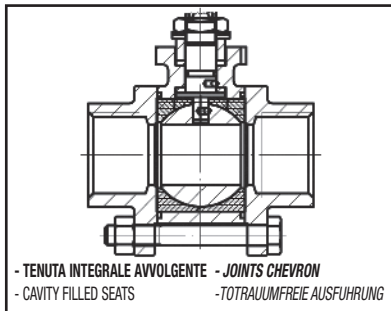
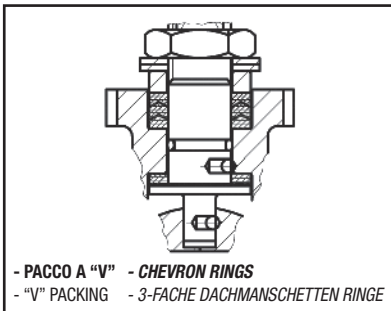

Proprietà riservata - A termine delle vigenti leggi questo documento non potrà essere copiato, riprodotto o comunicato ad altre persone o a ditte senza la nostra autorizzazione scritta. All rights reserved - No part of this reproduced or transmitted, in any form or by any means, electronic, mechanical, photocopying, recording or otherwise, without the prior permission of ALFA VALVOLE s.r.l.

Ed. 0008 / 02.16 / P0002

Le caratteristiche delle valvole, con esclusione di quelle regolamentate da Norme internazionali, possono essere oggetto di modifiche senza preavviso. Design and specifications are subject to change without notice except those established by international standards.



ALFA
VALVOLE s.r.l.

© 20010 CASOREZZO (Milano) - Italia -
VIALE DEL LAVORO, 19
Tel. 02.90296206 r.a. - Telefax 02.90296292 -
E-Mail: alfavalvole@alfavalvole.it - Sito internet: www.alfavalvole.it

BALL VALVES FULL BORE

ALFA 24K

PN 40 ÷ 63

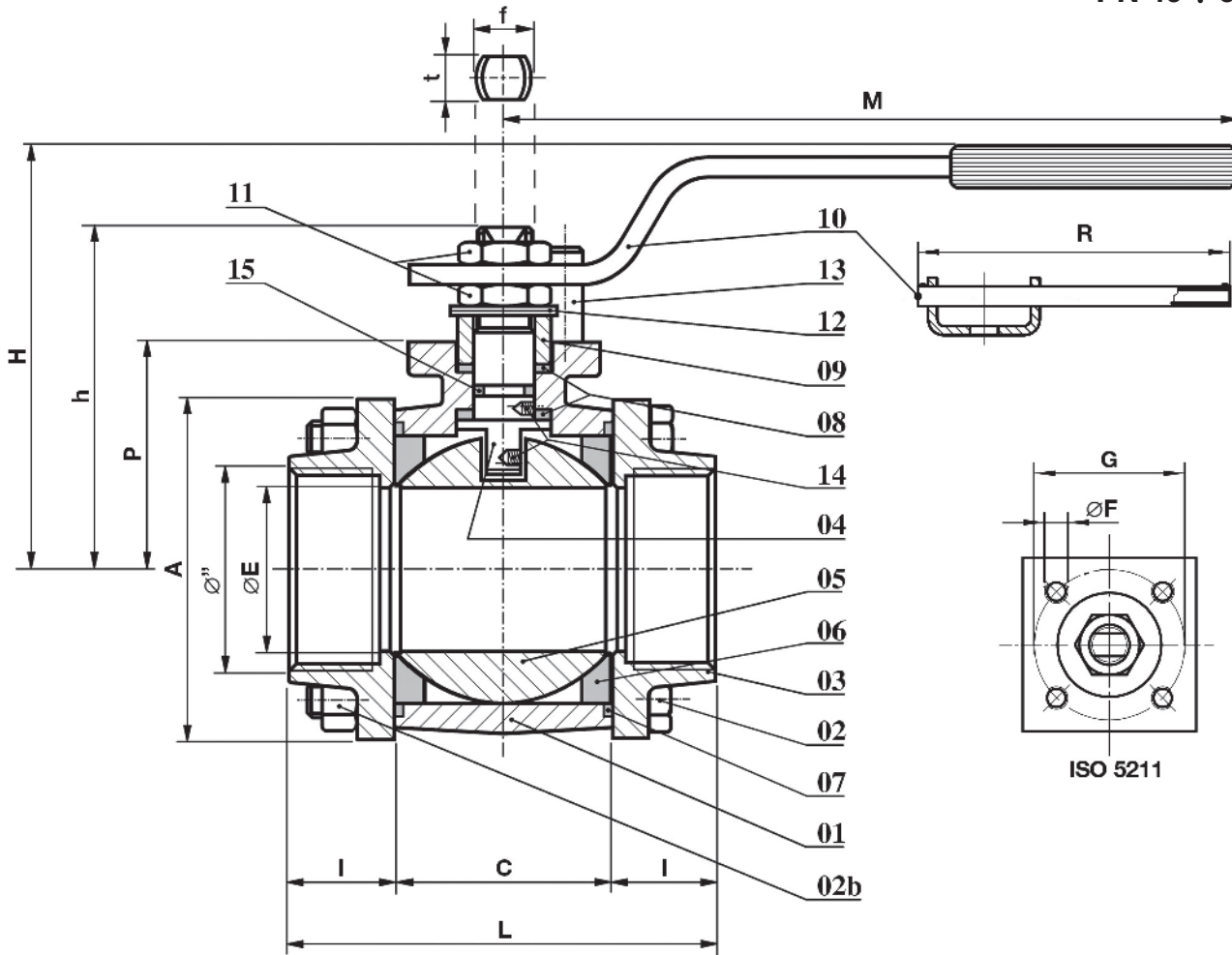

ACCOPPIAMENTO VALVOLA / ATTUATORE.
COUPLING VALVE / ACTUATOR.
ACCOMPLEMENT VANNE / ACTIONNEUR.
ANTRIEB / KUGELHAHN KUPPLUNG.

SCARTAMENTO DIN 3202 M3
FACE TO FACE ACCORDING TO DIN 3202 M3
ENGOMBREMENT SELON DIN 3202 M3
BAULANGE DIN 3202 M3

DIMENSIONI - DIMENSIONS - DIMENSIONS - ABMESSUNGEN

DN	06	10	15	20	25	32	40	50	65	80	100
Ø"	1/4"	3/8"	1/2"	3/4"	1"	1.1/4"	1.1/2"	2"	2.1/2"	3"	4"
ØE	10	10	14	19	24	29	38	48	64	76	95
L (GAS/NPT)	50	60	75	80	90	110	120	140	185	205	240
L (B.W./S.W.)											
M / R	145 / -	145 / -	150 / -	150 / -	185 / -	185 / -	275 / -	275 / -	380 / -	380 / -	440 / 500
H	53	53	84	87	95	99	118	125	143	149	185
h	40.5	40.5	52	54	69	72	95	101	122	127	151
P	25	25	33	36	43	48	63	67	82	88.5	105
A	38	38	47	53.5	61	67.5	82	96	120	184	216
C	20	20	26	31	35	42	52	64	90	100	125
I	15	20	24.5	24.5	27.5	34	34	38	47.5	52.5	57.5
f/t	8/5.7	8/5.7	10/6	10/6	12/8	12/8	16/10	16/10	22/14	22/14	30/18
02/02b	4/M5X40	4/M5X40	4/M6X50	4/M6X55	4/M8X65	4/M8X75	4/M10X90	4/M10X105	4/M12X135	6/M14X150	6/M14X180
Kg.	0.42	0.45	0.76	0.98	1.43	2.00	3.50	5.30	11.30	15.00	25.00
PN	64	64	64	64	64	64	64	40	40	40	40
ISO 5211	F03	F03	F03	F03	F03	F03	F03	F05	F05	F07	F07
ØF	M5	M5	M5	M5	M5	M5	M6	M6	M8	M8	M10
G	36	36	36	36	36	36	50	50	70	70	102

Ed. 0008 / 02.16 / P0002

Le caratteristiche delle valvole, con esclusione di quelle regolamentate da Norme internazionali, possono essere oggetto di modifiche senza preavviso.
Design and specifications are subject to change without notice except those established by international standards.



20010 CASOREZZO (Milano) - Italia -
VIALE DEL LAVORO, 19
Tel. 02.90296206 r.a. - Telefax 02.90296292 -
E-Mail: alfavalvole@alfavalvole.it - www.alfavalvole.it

Proprietà riservata - A termine delle vigenti leggi, questo documento non potrà essere copiato, riprodotto o comunicato ad altre persone o a ditte senza la nostra autorizzazione scritta.
All rights reserved - No part of this reproduced or transmitted, in any form or by any means, electronic, mechanical, photocopying, recording or otherwise, without the prior permission of ALFA VALVOLE S.R.L.

MATERIALI - MATERIALS - MATERIAUX - WERKSTOFFE

01	CORPO	BODY	CORPS	GEHÄUSE	ASTM A216 WCB	ASTM A351 CF8M
02	VITE	SCREW	VIS	SCHRAUBE	8.8 UNI 3740 ZINCATO - GALVANIZED - ZINGUE - VERZINKT	
02b	DADO CORPO	BODY STUD NUTS	CORPS ECROU	MUTTER GEHÄUSE	6S UNI 3740 ZINCATO - GALVANIZED - ZINGUE - VERZINKT	
03	CHIUSURA	CLOSURE	EMBOUT	FLANSCHSTUTZEN	ASTM A216 WCB	ASTM A351 CF8M
04	STELO	STEM	TIGE	SPINDEL	AISI 410	ASTM A479 F316
05	SFERA	BALL	BOULE	KUGEL	ASTM A479 F304	ASTM A479 F316
06	SEDI	SEATS	SIEGE	SITZRING	R.P.T.F.E.	
07	GUARNIZIONE CORPO	BODY GASKET	ANNEAU	DICHTUNGSRING	P.T.F.E. + GRAF.	P.T.F.E.
08	BUSSOLA	WASHER	JOINT DE TIGE	SPINDELABDICHTUNG	P.T.F.E. + GRAF.	P.T.F.E.
09	PREMIGUARNIZIONE	GLAND	PRESSE ETOUPE	STOPFBÜCHSE	CF9SMnPb36 UNI 4838 ZINCATO - GALVANIZED - ZINGUE - VERZINKT	ASTM A479 F304
10	LEVA	LEVER	LEVIER	HANDHEBEL	Fe37 UNI 7070 ZINCATO - GALVANIZED - ZINGUE - VERZINKT	
11	DADO CONTRODADO	NUT / LOCK NUT	ECROU / CONTRE ECROU	MUTTER / KONTERMUTTER	6S UNI 3740 ZINCATO - GALVANIZED - ZINGUE - VERZINKT	
12	MOLLE A TAZZA	SPRING WASHER	RONDELLES BELLEVILLE	TELLERFEDER	50CrV4 UNI 3545 ZINCATO - GALVANIZED - ZINGUE - VERZINKT	
13	DISPOSITIVO D'ARRESTO	STOP DEVICE	PLOT D'ARRET	ANSCHLAG VORRICHTUNG	8.8 UNI 3740 ZINCATO - GALVANIZED - ZINGUE - VERZINKT	
14	DISPOSITIVO ANTISTATICO	ANTISTATIC DEVICE	CONTACT ANTISTATIQUE	ANTISTATISCHE VORRICHTUNG	ASTM A479 F316	
15	O'RING STELO	STEM O'RING	O'RING TIGE	SPINDEL O'RING	VITON	

- ALFA GARANTISCE DAL 1971 UGUALI PARTI DI RICAMBIO. - ALFA FAIT GARANTIE POUR EGALES PARTIES D'ECHANGE DES 1971.
- ALFA GUARANTEES SPARE PARTS FOR SUPPLIES SINCE 1971. - ALFA GARANTIERT ERSATZTEILE FÜR LIEFERUNGEN SEIT 1971.

DIAGRAMMA - DIAGRAM - DIAGRAMME - DIAGRAMM

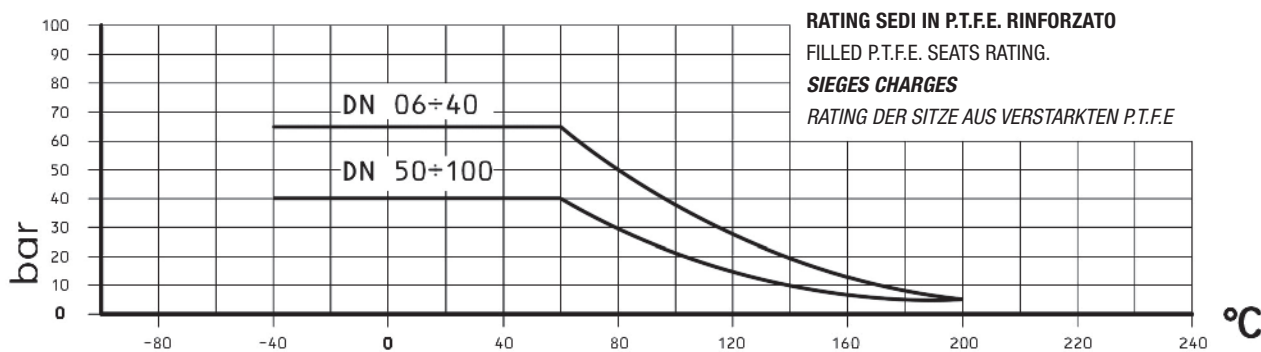

I valori riportati nei diagrammi sono puramente indicativi e possono variare in funzione delle condizioni di esercizio (fluido-pressione-temperatura).



ESECUZIONI - EXECUTIONS - EXECUTIONS - BESCHREIBUNG

STANDARD

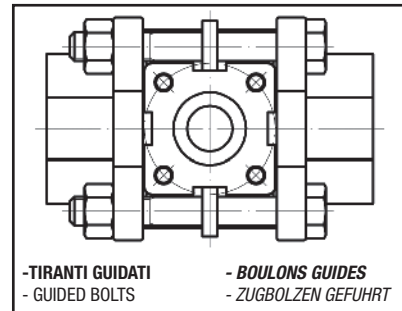
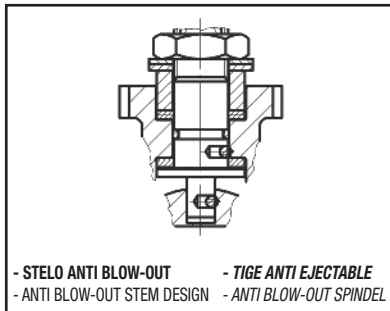
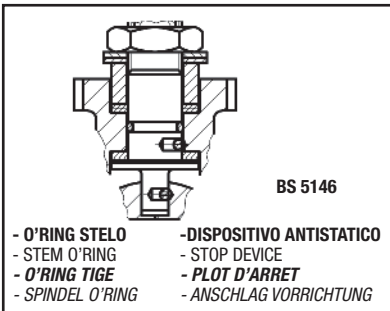
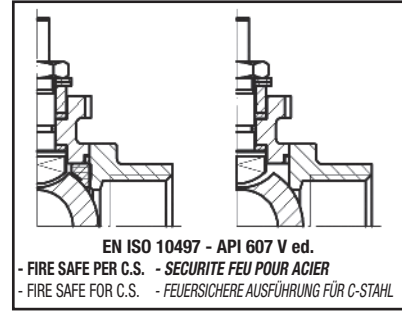
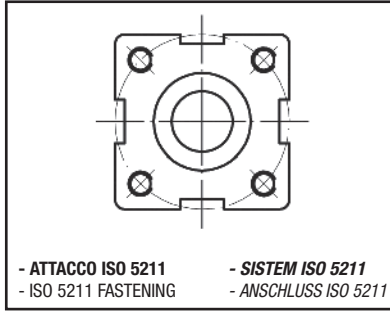
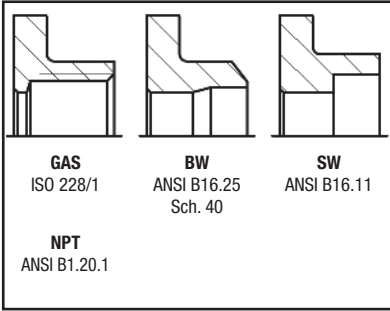

OPTIONAL

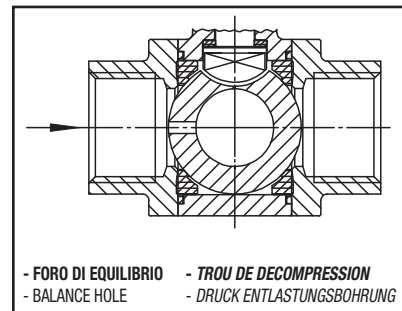
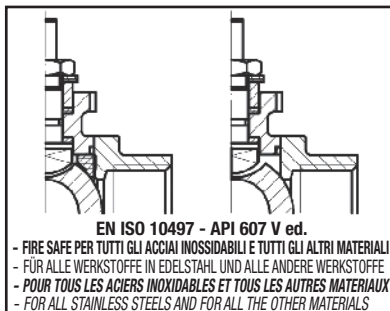
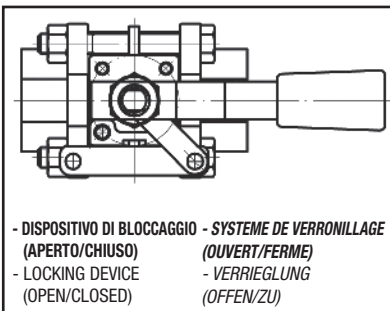
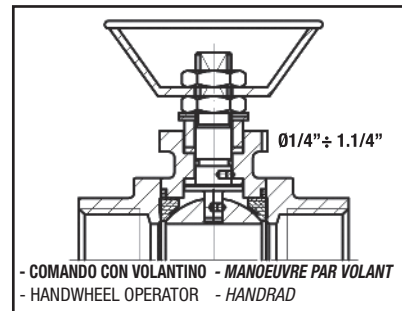
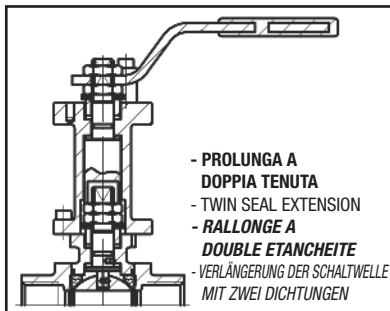
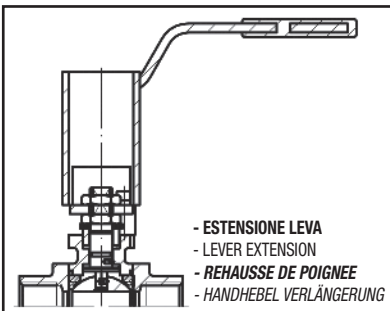
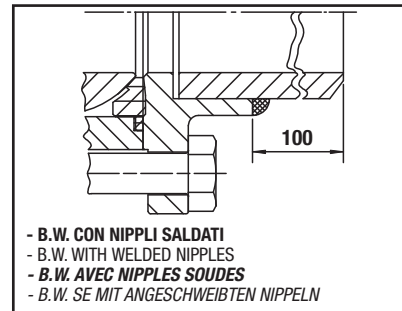
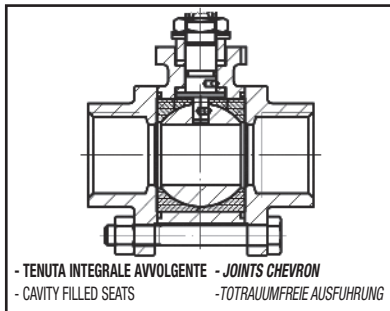
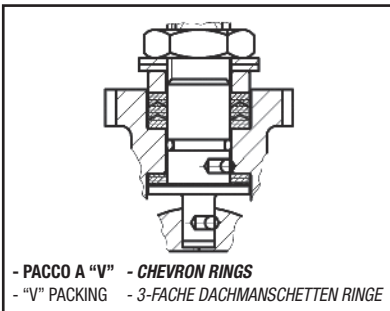

Proprietà riservata - A termine delle vigenti leggi questo documento non potrà essere copiato, riprodotto o comunicato ad altre persone o a ditte senza la nostra autorizzazione scritta. All rights reserved - No part of this reproduced or transmitted, in any form or by any means, electronic, mechanical, photocopying, recording or otherwise, without the prior permission of ALFA VALVOLE s.r.l.

Ed. 0008 / 02.16 / P0002

Le caratteristiche delle valvole, con esclusione di quelle regolamentate da Norme internazionali, possono essere oggetto di modifiche senza preavviso. Design and specifications are subject to change without notice except those established by international standards.